

ENVIRONMENTAL DEFENSE FUND, NATURAL RESOURCES DEFENSE COUNCIL,  
BREAST CANCER PREVENTION PARTNERS, CENTER FOR ENVIRONMENTAL  
HEALTH, CENTER FOR FOOD SAFETY, CENTER FOR SCIENCE IN THE PUBLIC  
INTEREST, CLEAN WATER ACTION, ENVIRONMENTAL WORKING GROUP, AND  
IMPROVING KIDS' ENVIRONMENT

June 4, 2017

Commissioner Gottlieb  
Food and Drug Administration  
Division of Dockets Management (HFA-305)  
Food and Drug Administration  
5630 Fishers Lane, Rm. 1061  
Rockville, MD 20852

Re: Objections and Request for Formal Evidentiary Public Hearing Regarding FDA's Denial  
of Perchlorate Food Additive Petition No. 4B4808, at Docket No. FDA-2015-F-537

Dear Commissioner:

The Food and Drug Administration's (FDA) May 4, 2017 denial of Food Additive Petition (FAP) No. 4B4808<sup>1</sup> is based on a flawed interpretation of the law and the science. This is troubling because perchlorate consumption by young children due to contamination of the food supply has demonstrably increased, threatening fetal and infant brain development.

The serious flaws in the agency's legal and scientific approach to perchlorate are numerous. The agency's decision and its underlying analysis grossly underestimated the extent to which perchlorate migrates from packaging and food handling equipment into dry food. In measuring this migration, FDA relied on a single study using a test designed for small packaging that was conducted by a company with a vested interest in the outcome. This migration test bears little relevance to the actual conditions of use of the perchlorate in bulk packaging allowed by FDA. It was not designed to assess the abrasive and compressive forces driving the migration of perchlorate into food from this use. It also was not relevant to the contribution of perchlorate into food from food handling equipment. Despite these serious shortcomings, the company's test still showed that perchlorate migrates into food.

In addition, the agency ignored its own data, which shows that its November 2005 approval allowing perchlorate in dry food polymeric (plastic) packaging and other plastic surfaces of food handling equipment likely contributed to the high, even shocking, levels of perchlorate found in dry baby food cereals by FDA in its Total Diet Study (TDS) samples collected from 2008 to 2012.<sup>2</sup> These rice, barley, oatmeal, and mixed grain cereals are the best measure of the impact of the agency's decision because these foods are usually handled dry from farm to store including

---

<sup>1</sup> FDA, Natural Resources Defense Council et al.; Denial of Food Additive Petition, 82 Fed. Reg. 20847, May 4, 2017.

<sup>2</sup> FDA, Survey Data on Perchlorate in Food – 2005-2006 and 2008-2012 Total Diet Study Results, accessed on May 29, 2017 at <https://www.fda.gov/Food/FoodborneIllnessContaminants/ChemicalContaminants/ucm077615.htm>.

when shipped in bulk and are not known to be contaminated by other sources of perchlorate such as contaminated water.

Before FDA's 2005 approval of the use of perchlorate, perchlorate concentrations in these baby food dry cereals were relatively low, with 1 of 20 samples (5%) at 11 parts per billion (ppb) and the rest below 3 ppb. In contrast, FDA's sampling after the 2005 decision indicated that 12 of 80 samples (15%) had perchlorate concentrations of over 3 ppb, including samples with concentrations of 173, 98, 67, 37, 24, and 16 ppb. These extremely high concentrations, well in excess of pre-approval results, suggest that they may result from use of the perchlorate-laden plastic in a limited number of food contact articles resulting in contamination of the baby food products.

These results are further confirmed by FDA's study comparing samples collected from 2008 to 2012, *after* FDA's approval to those collected from 2005 to 2006. This comparison shows that mean cumulative exposures increased 36% for infants 6-11 months of age; 24% for toddlers two years of age; and 11% for six-year old children.<sup>3</sup> Yet, unaccountably, the agency failed to mention these notable results in its denial of FAP No. 4B4808. Nor did FDA explain how, in light of these documented increases, the conditions of use continue to satisfy the agency's safety standard. Under the law, additives must be reasonably certain to cause no harm under the intended conditions of use, and FDA must so demonstrate given these increases in exposure for the most vulnerable consumers: infants, toddlers, and children.<sup>4</sup>

In improperly denying FAP No. 4B4808, FDA also explicitly refused to consider the cumulative effects of the perchlorate exposure resulting from this use when added to exposures from other sources of perchlorate in the diet, and from chemically- and pharmacologically-related substances. This assessment of cumulative effect is mandated by Section 402(c)(5) of the Federal Food, Drug and Cosmetic Act (FD&C Act) (21 U.S.C. § 348(c)(5)) and is essential to any evaluation of the safety of food additives. The denial is unlawful because it failed to consider the evidence that children and pregnant women are already exposed to significant levels of perchlorate as well as two pharmacologically-related substances, nitrates and thiocyanate, which are widely occurring in the diet.

Further, the agency's decision shows a disturbing failure to account for the accumulating body of evidence that perchlorate poses a risk of irreversible harm to the fetal and infant brain. Perchlorate is a toxic chemical and an identified endocrine disruptor that inhibits absorption of iodine by the thyroid.<sup>5</sup> Tests make clear that almost all Americans have perchlorate at some level in their bodies. Its inhibition of iodine absorption is important, because iodine is essential to making thyroid hormones that regulate the body's metabolism and orchestrate fetal and infant

---

<sup>3</sup> Abt, E, Spungenm, J, Pouillot, R, Gamalo-Siebers, M, Wirtz, M. Update on dietary intake of perchlorate and iodine from U.S. Food and Drug Administration's total diet study: 2008–2012. 2016. *Journal of Exposure Science and Environmental Epidemiology*. doi:10.1038/jes.2016.78. See <http://www.nature.com/jes/journal/vaop/ncurrent/abs/jes201678a.html>.

<sup>4</sup> 21 CFR § 170.3(i).

<sup>5</sup> Maffini, MV, Trasande, L and Neltner, T. Perchlorate and Diet: Human Exposures, Risks, and Mitigation Strategies. 2016. *Current Environmental Health Report* 3:107-117. DOI 10.1007/s40572-016-0090-3. See <https://www.ncbi.nlm.nih.gov/pubmed/27029550>.

brain development.<sup>6</sup> Evidence demonstrates that even short-term drops in the thyroid hormone T4 can threaten brain development, with long-lasting consequences.<sup>7</sup>

Many people fail to get sufficient iodine from natural sources in the diet. Iodine is added to table salt but it is not present in not sea salt or salt added to processed food. It is also added to animal feed to protect the animals.<sup>8</sup> People whose diets depend heavily on processed food are at significant risk of iodine deficiency. Vegans are also at risk of iodine deficiency because they do not get the iodine present in animal products.

In addition, pregnant women need higher levels of iodine to support fetal brain development. An estimated 20% of pregnant women have a significant iodine deficiency.<sup>9</sup> In an October 2016 report, the Environmental Protection Agency (EPA) indicated that these pregnant women cannot tolerate any exposure to perchlorate without greatly increasing the risk of harm to the fetal brain.<sup>10</sup> Yet, FDA's 2016 study indicates that women of childbearing age consume on average 0.09 to 0.11 micrograms of perchlorate per kilogram of body weight per day ( $\mu\text{g}/\text{kg}\text{-bw}/\text{day}$ ).<sup>11</sup> The agency did not consider this evidence in its decision, which is critical to whether a condition of use may no longer meet the reasonably certain of no harm safety standard at 21 CFR § 170.3(i).

For these reasons and others described in more detail below, we respectfully object to FDA's decision posted in the May 4, 2017, *Federal Register*<sup>12</sup> notice denying FAP No. 4B4808 and request that the agency:

- A. Revoke its 2005 approval of Threshold of Regulation (TOR) exemption No. 2005-006 allowing as much as 1.2 percent sodium perchlorate monohydrate in dry food packaging;<sup>13</sup>
- B. Issue a new § 189.301 (21 CFR 189.301) prohibiting the use of perchlorate as a conductivity enhancer in the manufacture of antistatic agents to be used in food contact articles; and
- C. Remove potassium perchlorate as an allowed additive in sealing gaskets for food containers in existing § 177.1210 (21 CFR 177.1210).<sup>14</sup>

---

<sup>6</sup> *Id.*

<sup>7</sup> *Id.*

<sup>8</sup> *Id.*

<sup>9</sup> *Id.*

<sup>10</sup> EPA, Biologically Based Dose Response Models for the Effect of Perchlorate on Thyroid Hormones in the Infant, Breast Feeding Mother, Pregnant Mother, and Fetus: Model Development, Revision, and Preliminary Dose-Response Analyses, 2016. See <https://www.regulations.gov/document?D=EPA-HQ-OW-2016-0438-0002>.

<sup>11</sup> Abt et al, 2016 at 5 Table 4.

<sup>12</sup> FDA, Natural Resources Defense Council et al.; Denial of Food Additive Petition, 82 Fed. Reg. 20847, May 4, 2017.

<sup>13</sup> Note that in 2016, FDA modified the description of TOR Exemption No. 2005-006 to expand its scope from polymeric packaging to any polymeric food contact article, which would include packaging and food handling and processing equipment. After reviewing the agency's documentation, it appears this change was made to be consistent with its original decision. While the agency fails to evaluate the implications of the change in its analysis, we maintain that it was obligated to do so.

<sup>14</sup> *Id.* at 20848.

We also request a formal evidentiary public hearing for each objection pursuant to 21 U.S.C. § 348(f)(1) and 21 CFR § 171.110).<sup>15</sup> Our objections are enumerated below.

**Objection 1: FDA relied on a flawed interpretation of the definition of a food additive in its Threshold of Regulation (TOR) Rule in improperly dismissing Request A regarding its approval of perchlorate as an anti-static agent in dry food polymeric food contact articles. This use of perchlorate is not eligible for TOR and must be considered as a food additive.**

FDA made myriad errors, detailed below, in determining that the use of perchlorate in dry food polymeric food contact articles (including packaging and food handling equipment) was not a food additive because the levels of the chemical migrating from the polymer are insignificant. We request a formal evidentiary public hearing to present this evidence and receive testimony from experts about the merits. (Note that we refer to the polymeric food contact articles containing up to 1.2% added perchlorate as perchlorate-laden plastic for simplicity.)

**Objection 1A: FDA failed to account for, or even acknowledge, its own scientific analysis, published in 2016, showing that perchlorate levels in young children increased significantly as a result of perchlorate contamination of food following its 2005 TOR decision.**

In 2008, FDA's scientists published a peer-reviewed study estimating dietary intake of perchlorate and iodine from its Total Diet Study (TDS) samples collected in 2005 and 2006.<sup>16</sup> On December 21, 2016, FDA's scientists updated the 2008 study with a peer-reviewed publication of TDS samples collected from 2008 to 2012.<sup>17</sup>

Both studies maintain that the mean perchlorate exposures remained below the reference dose (RfD) used by FDA and set by the National Academy of Science's (NAS) committee in 2005. Both studies also concluded that young children, including infants, have higher levels of perchlorate intake compared to adolescents and adults. While the 2016 study stated that the lower and upper bound estimates were comparable with those published in 2008, no further analysis was done to demonstrate whether the changes were statistically significant.<sup>18</sup>

On a webpage posted on May 3, 2017, the day before the denial of FAP No. 4B4808 was published in the *Federal Register*, FDA summarized the results of the 2016 study and

---

<sup>15</sup> For clarity, we are using FDA's description of each of the three requests in the decision rather than the one provided in the petition. We also use FDA's ordering of the requests and refer to them as Request A, B, or C.

<sup>16</sup> Murray, CM, Egan, SK, Kim, H, Beru, N and Bolger, PM. US Food and Drug Administration's Total Diet Study: Dietary intake of perchlorate and nitrate. 2008. *Journal of Exposure Science and Environmental Epidemiology* 18:571–580.

<sup>17</sup> Abt et al, 2016.

<sup>18</sup> *Id.*

compared levels of perchlorate in foods asserting that it “finds no overall change in perchlorate levels in food between 2005 and 2012.”<sup>19</sup> The agency stated that:

The 2008 – 2012 dataset contained higher average levels of perchlorate in some foods such as bologna, salami, and collard greens, and lower average levels of perchlorate in other foods such as plain bagels, boxed macaroni and cheese, and milk chocolate, when compared to the 2005 – 2006 dataset. These differences may be due to a number of factors, including variances in the region or season when the samples were collected and/or the increase in sampling in 2008-2012.<sup>20</sup>

Unaccountably, FDA failed to mention its own 2016 study and the underlying data in its denial of FAP No. 4B4808. As a matter of public record, FDA submitted the manuscript for the 2016 study for peer review on August 31, 2016<sup>21</sup>—more than eight months before it made its final decision on the food additive petition.

Our review of the 2016 study and the underlying data reveal that young children experienced a significant increase in mean perchlorate exposure between the two time periods (2005-2006 to 2008-2012). Using a methodology reported in FDA’s study and recommended by the World Health Organization, and the data in Table 4 of the 2016 study,<sup>22</sup> we estimate that mean exposures for young children increased:

- 36% for infants 6-11 months of age;
- 24% for toddlers two years of age; and
- 11% for six-year old children.

Figure 1 presents the changes graphically. The line for toddlers and six-year old children starts in 2006 because FDA’s analysis indicates that they did not eat any baby food, and only baby food was sampled in 2005.<sup>23</sup> In contrast, more than half of infants’ exposure came from baby food.<sup>24</sup>

Note that the years in agency’s TDS studies are based on the federal fiscal year. According to FDA’s 2008 article, its November 4, 2005, approval of TOR No. 2005-006 occurred after the first of the four sets of samples in 2006 had been collected.<sup>25</sup>

---

<sup>19</sup> FDA, Survey Data on Perchlorate in Food – 2005-2006 and 2008-2012 Total Diet Study Results, accessed on May 29, 2017 at

<https://www.fda.gov/Food/FoodborneIllnessContaminants/ChemicalContaminants/ucm077615.htm>.

<sup>20</sup> *Id.*

<sup>21</sup> Abt et al, 2016 at 1.

<sup>22</sup> Abt et al, 2016 at 5.

<sup>23</sup> FDA, Survey Data on Perchlorate in Food – 2005-2006 and 2008-2012 Total Diet Study Results and Murray et al., 2016 at Table 1 on 573.

<sup>24</sup> Abt et al, 2016 at Table 4 on 5.

<sup>25</sup> Murray et al, 2008.

FDA failed to consider this study in its denial of FAP No. 4B4808, and failed to report whether or not the increases it found in 2016 were statistically significant.

**Figure 1: Increase in estimated mean dietary intake of perchlorate by young children based on FDA’s Total Diet Study composite samples collected on Federal Fiscal Years 2005, 2006, and 2008 to 2012.**

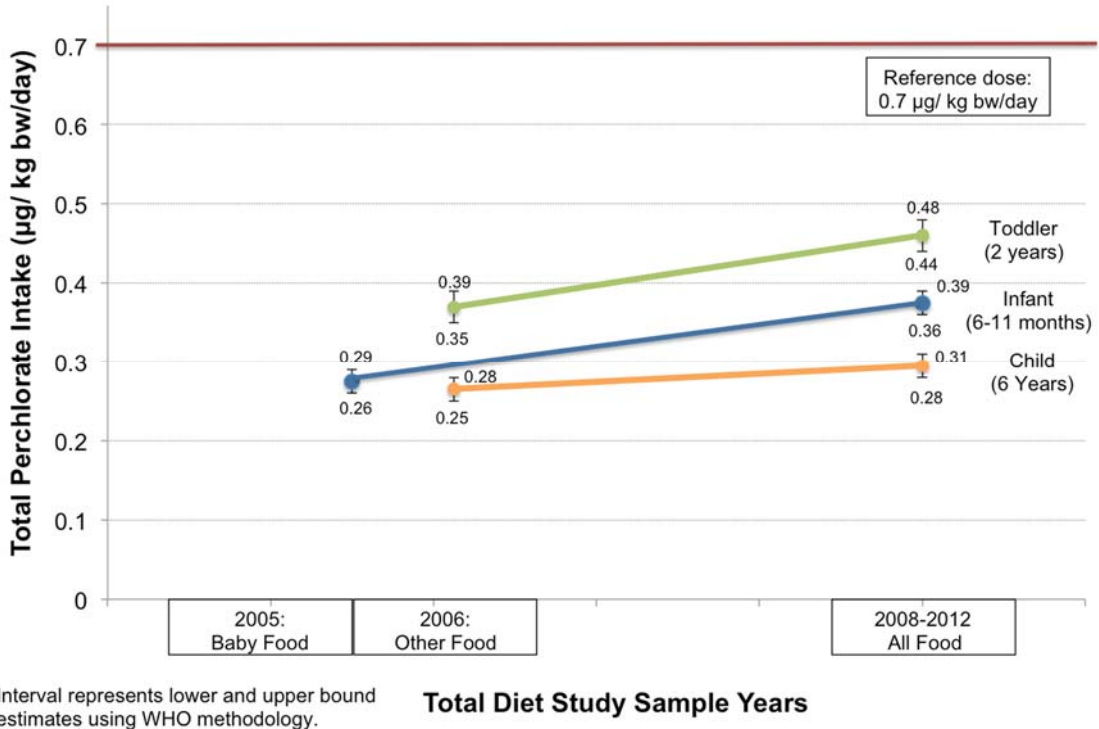

Further, FDA’s list of possible sources of perchlorate contamination includes use of perchlorate in solid propellants for rockets and missiles, fireworks, and certain munitions as well as lightning and nitrate-rich mineral deposits in Chile used as fertilizer in the US.<sup>26</sup> It fails to mention the intentional use of perchlorate approved by the agency in 2005 with TOR No. 2005-006.

FDA also does not acknowledge as a source the transformation of hypochlorite bleach into perchlorate that has been documented since 2011.<sup>27</sup> FDA allows bleach to be used as a food additive in the washing or to assist in lye peeling of fruits and vegetables as a food additive at 21 CFR § 173.315. Bleach is also commonly used as a disinfectant in food production pursuant to 40 CFR §§ 180.1054 and 180.1235.

As discussed in Objection 1E, these chemically-related exposures must be considered as part of the assessment of the cumulative effects.

<sup>26</sup> Abt et al, 2016 at 1 and 2.

<sup>27</sup> Sanford, BD, Pisarenko, AN, Snyder, SA, Gordon, G. Perchlorate, bromate, and chlorate in hypochlorite solutions: Guidelines for utilities. 2011. Journal of the American Water Works Association 103:6-12.

For these reasons, we request a formal evidentiary public hearing to present evidence and receive testimony from experts about the merits of this objection.

**Objection 1B: FDA failed to consider its own data from the Total Diet Study that showed dramatic increases in the types of food samples (baby food dry cereals) that are most likely to demonstrate the contamination from the use of perchlorate in dry food polymeric food contact articles following approval of that use by the agency in TOR No. 2005-2006.**

We closely examined all of the data FDA published in its 2008 and 2016 studies and on its webpage posted on May 3, 2017. First, we focused on four baby food types: rice, barley, oat, and mixed cereals. These cereals are the best measure of the impact of the agency's decision because these foods are usually handled dry from farm to store including when shipped in bulk and are not known to be contaminated by other sources of perchlorate such as contaminated water.<sup>28</sup>

As noted in FAP No. 4B4808, in 2004, the U.S. Patent Office issued a patent specifically referencing BASF's Irgastat P18, the anti-static perchlorate-laden ingredient added to polymeric materials described in TOR No. 2005-006, to be used in a flexible intermediate bulk container.<sup>29</sup> This type of container is used for dry products that flow easily. Anti-static properties are valuable because they dissipate static charges that can accumulate from the flowing ingredients without grounding.<sup>30</sup> In addition, we found a 2013 booklet on a BASF website on Irgastat P18 focused on the Chinese market that refers to the product's use for "bulk and industrial food and non-food contact packaging."<sup>31</sup>

Second, we examined the evidence regarding perchlorate levels in food that FDA collected before the agency approved TOR No. 2005-006 on November 4, 2005. As noted in Objection 1A, the TDS years are based on federal fiscal years, not calendar years. The TDS 2005 represented samples collected in October 2004, January 2005, April 2005, and July 2005.<sup>32</sup> Each sample result is a composite of three separate products bought in three separate cities in the region. For TDS 2006, only the October 2005 sample was collected before the TOR approval. Samples collected after October may

---

<sup>28</sup> In contrast, food types such as produce were likely affected by contaminated water supplies from industrial sources such as contamination of the Colorado River, use of perchlorate-contaminated Chilean fertilizer or from degradation of hypochlorite bleach used to wash, peel, or disinfect fruits and vegetables. Similarly dairy and processed meat may have been contaminated from being disinfected by degraded hypochlorite bleach in addition to perchlorate already present in dry ingredients stored in perchlorate-laden plastic bags.

<sup>29</sup> U.S. Patent Office, Inner Device for Neutralization of Electrostatic Charges from Material in Contact, US 2004/004804 A1, January 8, 2004.

<sup>30</sup> Wikipedia, Flexible intermediate bulk container, accessed on May 20, 2017 at [https://en.wikipedia.org/wiki/Flexible\\_intermediate\\_bulk\\_container](https://en.wikipedia.org/wiki/Flexible_intermediate_bulk_container).

<sup>31</sup> BASF, Solutions for Food Packaging, 2013. In the petition, we noted that we found the brochure at [http://chinaplas.basf.com/sites/default/files/brochure/Solutions%20for%20Food%20Packaging\\_English\\_2013\\_lo.pdf](http://chinaplas.basf.com/sites/default/files/brochure/Solutions%20for%20Food%20Packaging_English_2013_lo.pdf). The link is no longer working. We can provide a copy of the brochure.

<sup>32</sup> Murray at el, 2008.

have been affected depending on how quickly the marketplace adopted the newly approved product.

With these two filters, we identified food types designated by FDA as baby food and dry cereal. We excluded two baby food dry cereals that had added fruit because perchlorate may have come from washing the fruit with hypochlorite bleach, pursuant to 21 CFR § 173.315, that may have partially degraded to perchlorate. The four types are:

- Baby Food (BF), cereal, barley, dry, prepared with water;
- BF, cereal, oatmeal, dry, prepared with water;
- BF, cereal, rice, dry, prepared with water; and
- BF, cereal, mixed, dry, prepared with water.<sup>33</sup>

**Figure 2. Perchlorate levels in dry rice, barley, oatmeal, and mixed grain cereal collected by FDA as part of its Total Diet Study and designated by FDA as baby food in 2005 and in 2008 to 2012.**

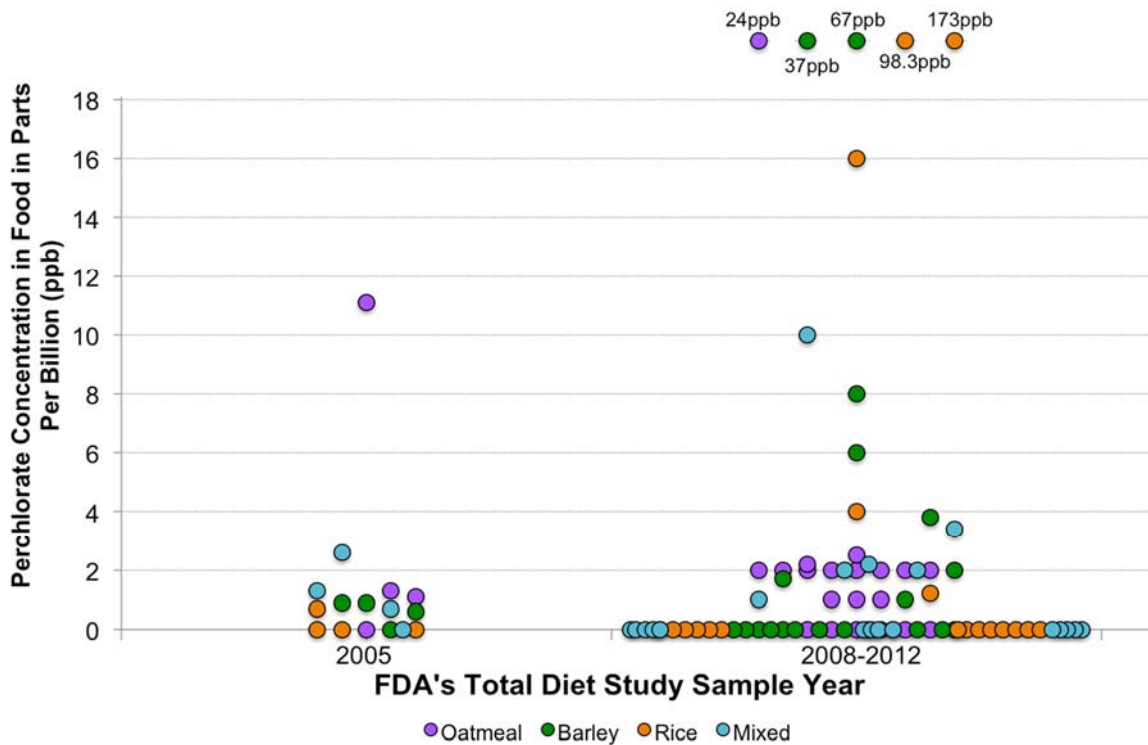

Derived from FDA "Survey Results on Perchlorate in Food - 2005-2006 and 2008-2012 Total Diet Study Results"  
 Non-detect results assigned to 0ppb

The results are provided in Figure 2. In 2005, only 5% (1 of 20) of the composite dry cereal baby food samples exceeded 3 ppb; a composite sample of oatmeal cereal had 11.1 ppb. In comparison, in 2008-2012, 15% (12 of 80) of the composite dry cereal baby food samples exceeded 3 ppb – or three times more than before FDA’s approval of TOR No 2005-006. Even more significantly, 6 of the composite samples had levels greater than the highest levels that had been found in 2005 (11.1 ppb):

<sup>33</sup> Note that FDA took the dry composite product and prepared it with water in their laboratory.



- Baby food rice cereal had levels of 173 ppb, 98.3 ppb and 16 ppb;
- Baby food barley cereal had levels of 37 ppb and 67 ppb; and
- Baby food oatmeal cereal had one composite sample of 24 ppb.

Since each of these results is a composite sample from a blend of the food type collected by FDA staff in three separate cities within the same region,<sup>34</sup> it is entirely possible that the level in a single sample with high levels could have been blended with two samples with non-detectable levels. That means that a single sample could have had perchlorate levels nearly three times greater than the level reported. (For simplicity and clarity, we placed the higher levels outside the scale in Figure 2.)

The perchlorate concentrations in composite samples were greater than seen before the approval. We maintain that there is a reasonable possibility that these concentrations were high because of contamination resulting from FDA's approval of TOR No. 2005-006. After the decision, it is possible that at one or more steps in food production and processing involved in moving the product from farm to store, a dry ingredient was likely shipped in a flexible intermediate bulk container or other similar packaging and contaminated with high levels of perchlorate from the plastic.

For these reasons, we request a formal evidentiary public hearing to present evidence and receive testimony from experts about the merits of this objection.

**Objection 1C: The migration test performed by BASF and affirmed by FDA showed migration occurring from the perchlorate-laden plastic. However, due to the test design, both BASF and FDA grossly underestimated the extent of the migration that is likely, resulting in a flawed exposure estimate.**

In response to FAP No. 4B4808, BASF conducted a migration test<sup>35</sup> on the perchlorate-laden plastic and submitted it to the docket as a comment. FDA relied on this migration test in its analysis of the exposure estimate. The test consisted of folding a 4-square-inch sample of the perchlorate-laden plastic in half and placing it upright in the middle of a small dish. Then 12 grams of a dry food simulant known as Tenax were added around the sample, covering it completely. The small dish was then capped and held for 2 hours at 104°F. This test was repeated for longer contact times (1 day, 4 days and 10 days). At the end of the time period, the plastic sample was removed, and the Tenax was analyzed for perchlorate. The report does not explain precisely how vigorously the Tenax was added to the small dish.

---

<sup>34</sup> FDA, Study Design, accessed May 29, 2017 at <https://www.fda.gov/Food/FoodScienceResearch/TotalDietStudy/ucm184232.htm>.

<sup>35</sup> BASF, Migration Report: Migration of Sodium Perchlorate from Low Density Polyethylene containing 20% Irgastat P18 into Dry Food Simulant, 2015. The report consists of five documents in the docket for the petition: FDA-2015-F-0537-0019 for main report; FDA-2015-F-0537-0020 for Appendix A of the report; FDA-2015-F-0537-0021 for Appendix B of the report; FDA-2015-F-0537-0022 for Appendix C of the report; and FDA-2015-F-0537-0023 for Appendix D of the report. We refer to all five documents as the BASF migration test.

BASF found detectable levels of perchlorate in the Tenax at all four time periods with no increase in concentration over time. The levels were not sufficient to be reliably quantifiable. The report said the results suggest “that the perchlorate found in the simulant was most likely caused by surface abrasion.”<sup>36</sup> There is no indication in the BASF testing report that the company placed the dishes containing the plastic and Tenax in an environment where the solid simulant is moved around in a manner that would create conditions of use wherein abrasion would be likely to occur. The fact that it was detected at all indicates just how likely migration would occur from the perchlorate-laden plastic with even the slightest abrasion.

FDA repeatedly refers to this test as providing a worst-case estimate.<sup>37</sup> This is entirely inaccurate; the agency fundamentally misunderstands the serious limitations of the test’s ability to evaluate the impacts of abrasion, compression, and heat, and how significantly it varied from the real-world uses of the product. The test is focused on migration through leaching or volatilization of chemicals mostly from final packaging and *not* abrasion.

Indeed, FDA appears to not to have considered the purpose of perchlorate as an anti-static agent that facilitates the flow of dry materials. A static charge is likely to be generated when a dry solid flows. When the solid is flowing across a non-conductive material, such as a typical plastic, the static charge can accumulate. If the accumulated charge reaches a high enough level, it can produce a spark that can ignite the powder and cause a dust explosion. As an analogy, when you shuffle your shoes on carpet you build up a charge that forms a spark when you touch metal that is grounded. The more you shuffle, the greater the electrical charge. The purpose of an anti-static agent such as perchlorate is to dissipate the charge that might otherwise accumulate from the flowing dry food.

Therefore, any migration test that does not evaluate in a serious manner the effects of the flowing dry food across the surface of the perchlorate-laden plastic could not possibly be “worst-case” scenario. In the BASF migration report, the only abrasion occurred either when the half-cup of Tenax was placed around the 2-square-inch, double-sided sample or when the plastic sample was removed. The fact that detectable migration occurred under such a delicate testing condition, compared to a real-use scenario, and at all times tested is evidence of how serious the contamination from perchlorate-laden plastic may be in far more abrasive actual uses.

Compare these test conditions to the most likely use of the perchlorate-laden plastic in real life – as an anti-static agent in a flexible intermediate bulk container, either as a component in the bag or as a liner. This is precisely what was proposed in the patent application that specifically mentioned BASF’s Irgastat P18 product. Figure 3 is from that patent application that was approved by the US Patent Office in January 2004.<sup>38</sup>

---

<sup>36</sup> BASF, Migration Report, 2015. See note 34.

<sup>37</sup> FDA, FAP 4B4808 (formerly PNC 1447) – Submission dated 7-31-14 (received 8-4-14), 10-15-14 (received 10-17-14) and 12-5-14 (received 12-8-14). Chemistry evaluation, March 31, 2017, Docket No. FDA-2015-F-0537-0038.

<sup>38</sup> U.S. Patent Office, U.S. Patent Application Publication, Inner Device for Neutralization of Electrostatic Charges from Material in Contact, U.S. 2004/0004804 A1, January 8, 2004.

For scale, a flexible intermediate bulk container may contain 2000 pounds of dry food. Figure 4 provides an example of a typical container. It is filled by pouring the product into the bag through the opening that is tied off at the top of the container in the photo. It is emptied by inverting the bag or untying an opening at the bottom of the bag. The flow is controlled by throttling the opening. With each operation, the fast flowing product abrades the plastic. If the product were not flowing fast, the anti-static agent would not be needed.

**Figure 3. Figure of flexible intermediate bulk container from U.S. Patent Office, Inner Device for Neutralization of Electrostatic Charges from Material in Contact, US 2004/004804 A1, January 8,**

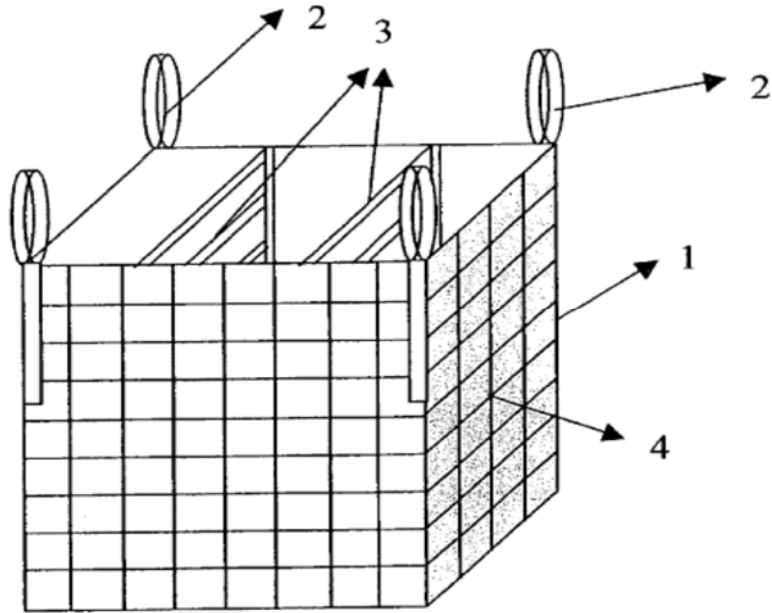

**Figure 4. Image of a common flexible intermediate bulk container**



In addition, the Tenax simulant in BASF's migration test had virtually no compression pressure forcing it into the perchlorate-laden plastic, and the tests were run at 104°F. However, in a flexible intermediate bulk container holding 1-ton of dry food, the compression pressures are significant, especially on a trans-oceanic shipment with other bags stacked upon it. The dry food would be more likely to be pressed into the plastic and, possibly, carry some of the perchlorate with it when it was dumped from the flexible intermediate bulk container. The migration test also was not representative of the back of a hot trailer, where temperatures reach 140°F.<sup>39</sup>

Clearly, reality represents a far greater chance for migration of perchlorate into food than was represented by BASF's migration test—a test that FDA is simply incorrect in representing as a worst case scenario. As a result of FDA's misunderstanding of the application, the agency grossly underestimates the amount of perchlorate that migrates into the dry food. This would explain the high levels of perchlorate found in the baby food dry cereals, described in Objection 1B, from the agency's TDS composite samples collected in 2008-2012 (but not in 2005).

For these reasons, we request a formal evidentiary public hearing to present evidence and receive testimony from experts about the merits of this objection.

**Objection 1D: FDA's exposure estimate considered that food would contact the perchlorate-laden plastic only once in its journey from farm to store. But its decision allowed the plastic to be used throughout the process for all dry food ingredients or additives. As a result, FDA underestimated the probable exposure from this use.**

FDA's exposure estimate is predicted on the flaw assumption that the food would only contact the perchlorate-laden plastic once. As made clear in FAP No. 4B4808, FDA's online posting of the use limitations contained significant misstatements of the conditions of use. From 2005 to 2015, FDA stated that the perchlorate could be used:

As a conductivity enhancer in the manufacture of antistatic agents at a maximum concentration of 4 percent by weight in the finished article for use in contact with dry foods.<sup>40</sup>

After reviewing FDA's response to a Freedom of Information Act (FOIA) request regarding TOR No. 2005-006, the petitioners alerted FDA in the food additive petition that the 2005 FDA decision limited perchlorate to 1.2% in the finished article, not 4% as FDA had indicated online. Also, the online statement erroneously allowed perchlorate in any material – not just polymeric material – even though FDA limited in its approval to polymeric materials. While BASF would have known that the description was wrong, its competitors were entitled to rely on the description to develop and market their own

---

<sup>39</sup> International Safe Transit Association, *ISTA Temperature Product – Data Summary*, 2002. See [https://www.ista.org/forms/ISTA\\_Temperature\\_Report-2002.pdf](https://www.ista.org/forms/ISTA_Temperature_Report-2002.pdf).

<sup>40</sup> FAP No. 4B4808, page 5.

version of the product. There is no obligation for BASF's competitors to notify FDA when they introduced a product as long as it was consistent with the on-line decision. As a result, consumers exposure could have been more than triple the estimate on which FDA's safety decision was based.

On August 17, 2015, FDA corrected the online description of the use limitations, writing that they were as follows:

As a conductivity enhancer in the manufacture of antistatic agents for use in polymeric food packaging. The food contact substance may be used at a level not to exceed 1.2 percent by weight of the finished polymer. The finished polymer may be used in contact with Food Type VIII only.<sup>41</sup>

The change limited the use of the perchlorate to polymeric materials and to 1.2% but also to packaging. FDA's approval of TOR No. 2005-006, obtained by the petitioners only as a result of a FOIA request, was not limited to packaging.

Without notifying the petitioners, unlike in August 2015, FDA apparently revised the online description again, widening use from "food packaging" to "finished articles." It currently says perchlorate may be used:

As a conductivity enhancer in the manufacture of antistatic agents for use in polymeric finished articles. The food contact substance may be used at a level not to exceed 1.2 percent by weight of the finished polymer. The finished article may be used in contact with Food Type VIII only.<sup>42</sup>

In the *Federal Register* notice, FDA says the change occurred on September 16, 2016.<sup>43</sup> However, the webpage says it was updated on July 27, 2016. We cannot explain the discrepancy.

These changes are significant since, as noted above, any person is entitled to rely on the webpage descriptions. BASF's competitors could have made a product that contained 4% perchlorate based on the original description. Since FDA provided no notice to the public of changes made to the online description until the ninth page of its denial of FAP No. 4B4808 in the May 4, 2017 *Federal Register*, food manufacturers may not have been tracking it. In the notice, FDA does not explain why it did not use the *Federal Register* notice method described in 21 CFR § 170.39(g) to alert competitors to the changes in the online notice.

In these objections, we will consider the current description of TOR No. 2005-006. This description allows the ingredients and other food additives in the final product to contact

---

<sup>41</sup> Email from FDA's Paul Hongifort to Tom Neltner, coordinator for petitioner on August 31, 2015 alerting Neltner to the change in the on-line description of TOR No. 2005-006.

<sup>42</sup> FDA, TOR No. 2005-006, accessed on March 30, 2017 at <https://www.accessdata.fda.gov/scripts/fdcc/?set=TOR&id=2005%2D006>.

<sup>43</sup> FDA, Natural Resources Defense Council et al.; Denial of Food Additive Petition, 82 Fed. Reg. 20847, May 4, 2017 at 20855.

the perchlorate-laden plastic many times without limit, not once as FDA assumed in its exposure assessment it used to deny FAP No. 4B4808. In the real life of a global food supply, the many dry food ingredients and food additives used to move food from farm and factory to fork will contact the perchlorate-laden plastic many times with each contact adding more perchlorate.

For example, the rice that may have ended up in the baby food dry rice cereal described in Objection 1C with 173 ppb of perchlorate likely contacted perchlorate-laden plastic food contact articles as it moved from harvest in the field to a silo for drying and then again when it moved from the silo to a production facility for further processing, such as screening and milling. From there, the rice would have been put in a new package for shipment to another production facility. At each of these steps, the rice could contact the perchlorate-laden plastic packaging that may or may not have been previously used. And with each process of filling and emptying the packaging, the dry food could gain more perchlorate through abrasion.

Moreover, food ingredients and food additives would also be contacting the perchlorate-laden plastic used in food handling equipment such as chutes, conveyor belts, grinders and screens.

Yet, despite this complexity in the supply chain, FDA's decision essentially assumes only a single contact between the food and perchlorate-laden plastic. This flawed logic is inherent in its guidance and its exposure calculations. For these reasons, we request a formal evidentiary public hearing to present evidence and receive testimony from experts about the merits of this objection.

**Objection 1E: FDA explicitly and unlawfully failed to consider the cumulative effects of other sources of perchlorate in the diet and of chemically- or pharmacologically-related substances, as required in the law and its definition of safety.**

Section 402(c)(5) of the FD&C Act (21 U.S.C. § 348(c)(5)) mandates that FDA specifically consider three relevant factors when evaluating a food additive petition:

- (A) the probable consumption of the additive and of any substance formed in or on food because of the use of the additive;
- (B) the cumulative effect of such additive in the diet of man or animals, taking into account any chemically or pharmacologically related substance or substances in such diet; and
- (C) safety factors which in the opinion of experts qualified by scientific training and experience to evaluate the safety of food additives are generally recognized as appropriate for the use of animal experimentation data.<sup>44</sup>

---

<sup>44</sup> Section 402(c)(5) of the FD&C Act (21 U.S.C. § 348(c)(5)).

The agency explicitly refused to consider the second factor deemed relevant by Congress (B above). Instead, it reviewed the petition using criteria in its Threshold of Regulation Rule (TOR Rule) at 21 CFR § 170.39(a) under the mistaken assumption that would suffice. The TOR rule was issued in 1995 based on the agency's analysis of toxicological data that it found enabled FDA to "establish a threshold level below which dietary exposures to substances used in food-contact articles are so negligible as to pose no public health or safety concerns."<sup>45</sup> The agency explained:

As part of this process, the agency is establishing two types of thresholds for the regulation of substances used in food-contact articles. The first type of threshold will exempt from regulation those substances whose use in food-contact articles results in a dietary concentration of the substance of 0.5 ppb or less. The second type of threshold will exempt regulated direct food additives from regulation when used in food-contact articles at levels that result in a dietary exposure of 1 percent or less of the acceptable daily intake (ADI) for the additive.

...

As stated in the proposal, a 1-percent ADI threshold for regulated direct food additives used in food-contact articles is appropriate because this level of dietary exposure will contribute only a small fraction of the ADI of a substance and, therefore, will be well within the margin of safety for those direct food additives with small cumulative dietary exposures. For substances with high cumulative dietary exposures resulting from regulated direct food additive uses, a level of exposure that is 1 percent of the ADI would be within the margin of error for the estimated daily intake. It would, therefore, not significantly affect the cumulative dietary exposure, even in the event that a particular substance is granted exemptions for several different types of uses in food-contact articles.<sup>46</sup>

The agency explained that in a 1979 decision in *Monsanto v. Kennedy*,<sup>47</sup> the United States Court of Appeals for the District of Columbia Circuit authorized the type of approach laid out in the TOR rule when it considered the use of an acrylonitrile copolymer in beverage bottles. Monsanto contended there was no detectable migration into the beverage and that any that may be occurring was insignificant. The court said that:

Thus, the Commissioner may determine based on the evidence before him that the level of migration into food of a particular chemical is so negligible as to present no public health or safety concerns, even to assure a wide margin of safety. This authority derives from the administrative discretion, inherent in the statutory scheme, to deal appropriately with De minimis situations.<sup>48</sup>

---

<sup>45</sup> FDA, Food Additives; Threshold of Regulation for Substances Used in Food-Contact Articles, Final Rule, 60 Fed. Reg. 36582, July 17, 1995.

<sup>46</sup> *Id.*

<sup>47</sup> *Monsanto v. Kennedy*, 613 F.2d 947 (D.C. Cir. 1979).

<sup>48</sup> *Id.* at 955.

The agency viewed this approach as satisfying the first of three considerations mandated by Section 402(c)(5) of the FD&C Act (21 U.S.C. § 348(c)(5)). Under that provision, when evaluating a food additive petition, the agency must consider “the probable consumption of the additive and of any substance formed in or on food because of the use of the additive.” (Section 402(c)(5)(A) of the FD&C Act (21 U.S.C. § 348(c)(5)(A)). The agency presumes that the migration test accurately represents real-world exposures; in this case, as we have presented in Objection 1C, the migration test relied upon by FDA does not, and indeed, grossly underestimates likely exposures and fails to model real-world conditions of use.

Moreover, while it should be debated whether FDA’s approach satisfies that first of the FFDCA’s three criteria in §402(c)(5),<sup>49</sup> nowhere in the notice for the proposed rule<sup>50</sup> or the final rule does the agency explain how the rule addresses the second of the three mandatory considerations under that paragraph. That second provision mandates that the agency consider “the cumulative effect of such additive in the diet of man or animals, taking into account any chemically or pharmacologically related substance or substances in such diet.” (Section 402(c)(5)(B) of the FD&C Act (21 U.S.C. § 348(c)(5)(B))).

Unlike the first consideration, the second requires that the agency take into account chemically-related substances in the diet as well as pharmacologically-related substances in the diet. The factor is focused on the entire diet and not just FDA-approved uses.

In denying FAP No. 4B4808, the agency made a bold and largely unsupportable claim that it may disregard this mandate:

The use of a food contact substance that is exempted from regulation as a food additive under FDA’s TOR regulation is not subject to the factors that apply to the proposed use of a food additive under section 409(c)(5)(B) of the FD&C Act and § 170.3(i)(2) [FDA’s definition of safety]. Rather, when we exempt a food-contact use of a substance from regulation as a food additive, our TOR regulation ensures the safety of this food-contact use by setting extremely low limits on migration levels so that its proposed use results in a negligible dietary concentration, and requiring that the substance not be a carcinogen. A premise of the TOR regulation is that if a substance meets these requirements, it presents no other health or safety concerns (see § 170.39(a)(2)). In determining whether the use of a substance qualifies for a TOR exemption, cumulative exposure to a substance is not considered under the TOR regulation because the dietary exposure from the use of a substance that is at or below the threshold of regulation is negligible. Thus, § 170.39(a)(2)(i) provides that the only dietary exposure that is relevant to whether the use of a substance qualifies for a TOR

---

<sup>49</sup> We note, for example, that both the D.C. Circuit, *see Public Citizen v. Young*, 831 F. 2d 1108 (D.C. Cir. 1987), *cert denied* 485 U.S. 1006 (1988), and the Ninth Circuit, *see Les v. Reilly*, 968 F. 2d 985 (9<sup>th</sup> Cir. 1992) *cert denied* 507 U.S. 950 (1993), have substantially circumscribed the availability of a *de minimis* exception under the FFDCA.

<sup>50</sup> FDA, Food Additives; Threshold of Regulation for Substances Used in Food-Contact Articles, Proposed Rule, 58 Fed. Reg. 52719, October 12, 1993.



exemption from regulation as a food additive is the dietary exposure resulting from the use in question.<sup>51</sup>

This interpretation would allow the agency to approve an additional exposure to a substance that already exceeds the acceptable daily intake (ADI) for that chemical. As described in Objection 1E, that is already occurring for some vulnerable populations. Such a view is contrary to a plain reading of the statute as well as the reasoning of the TOR regulation.

We contend that this is exactly what FDA did when it approved perchlorate use. The agency failed to consider the following key factors as directed in the statute: other sources of perchlorate exposure; and concurrent exposures to pharmacologically related substances. These sources include:

- Perchlorate from degraded hypochlorite bleach used as:
  - Direct food additive to wash or assist in lye peeling of fruits and vegetables at 21 CFR § 173.315; and
  - Disinfectant in food production pursuant to 40 CFR §§ 180.1054 and 180.1235.
- Concurrent exposure to nitrates and thiocyanates, two substances pharmacologically-related to perchlorate that increase the risk of harm from perchlorate.<sup>52</sup>

For these reasons, we request a formal evidentiary public hearing to present evidence and receive testimony from experts about the merits of this objection.

**Objection 1F: FDA accepted the 12-year old National Academy of Science committee’s reference dose without adequately considering the more recent science showing it is insufficient to protect fetuses of pregnant women with severe iodine deficiency and children exposed to levels above said dose.**

A safe amount or reference dose (RfD) represents how much perchlorate can be consumed without developing adverse effects during a lifetime of exposure. It’s usually expressed as the amount of a chemical per kilogram of body weight a person can safely consume on a daily basis.

The current RfD is 0.7 micrograms (µg) of perchlorate per kilogram of body weight per day (µg/kg bw/d). It was developed 12 years ago in 2005 by a National Academy of Sciences (NAS) committee<sup>53</sup> and has since been used by some regulatory agencies as the value against which exposure to perchlorate from, for instance, drinking water and food would be compared.

---

<sup>51</sup> FDA, Natural Resources Defense Council et al.; Denial of Food Additive Petition, 82 Fed. Reg. at 20855.

<sup>52</sup> Maffini et al., 2016.

<sup>53</sup> National Research Council; Division on Earth and Life Studies; Board on Environmental Studies and Toxicology. Health Implications of Perchlorate Ingestion. 2005. <https://www.nap.edu/catalog/11202/health-implications-of-perchlorate-ingestion>.

The RfD was based on the 2002 Greer et al.<sup>54</sup> study where adult men and women were given different amounts of perchlorate every day for two weeks. The researchers subsequently measured how much or how little perchlorate inhibits iodine from entering the thyroid gland. Although the lowest dose of 7 µg/kg bw/d inhibited iodine uptake by 5%, the NAS committee concluded that it did not have a biological effect. Because the study subjects were adults, the NAS Committee applied an uncertainty factor of 10 to protect the most sensitive population: fetuses of pregnant women with hypothyroidism or iodine deficiency.

In the developing the RfD, the NAS Committee dismissed transient drops in thyroid hormone as adverse because “biological mechanisms exist that allow the body to compensate and return these levels to normal without causing adverse effects on human health.”<sup>55</sup> This is an assumption based on healthy adult individuals that are not pregnant and have normal iodine intake. It does not apply during fetal organ development or to pregnant women with insufficient iodine intake. Normal fetal brain development is the result of an undisturbed harmonious interaction among cells, and between cells and hormones. If a step is missed or occurred at the wrong time, the fetus does not compensate. If developmental processes are disrupted by lowering thyroid hormone due to perchlorate exposure, this most likely creates permanent deficits.

Perchlorate interferes with the thyroid gland’s ability to use iodine from the diet, a critical element to make a thyroid hormone, known as T4. This hormone plays an important role in the body regulating metabolism and, most critically, fetal and infant brain development.<sup>56</sup> Inadequate levels of T4 during pregnancy<sup>57</sup> and in the first years of life are likely to affect a child’s ability to reach his or her full intellectual potential. There is evidence that children born to mothers with borderline iodine deficiency that were exposed to perchlorate in the first trimester show signs of delayed development.<sup>58</sup>

FDA adopted the NAS Committee approach and endorsed the RfD without addressing or questioning its level of protection in light of more recent information. Unlike FDA, other government agencies and scientific bodies have reviewed the full array of data and conducted more recent analyses and either developed their own RfD or suggested different approaches to establish a higher level of protection. In a 2010 publication,<sup>59</sup> the

---

<sup>54</sup> Greer, MA, Goodman, G, Pleus, RC, Greer, SE. Health effects assessment for environmental perchlorate contamination: The dose response for inhibition of thyroidal radioiodine uptake in humans. 2002. Environmental Health Perspectives 110:927-937.

<sup>55</sup> FDA, FAP 4B4808 Toxicology Analysis, March 31, 2017, Docket FDA-2015-F-0537-0042, pages 9-10.

<sup>56</sup> Maffini et al, 2016.

<sup>57</sup> EPA, Science Advisory Board. Advice on Approaches to Derive a Maximum Contaminant Level Goal for Perchlorate, 2013. See <https://www.epa.gov/dwstandardsregulations/perchlorate-drinking-water>.

<sup>58</sup> Taylor, PN, Okosieme, OE, Murphy, R, Hales, C, Chiusano, E, Maina, A, Joomun, M, Bestwick, JP, Smyth, P, Paradise, R, Channon, S, Braveman, LE, Dayan, CM, Lazarus, JH, Pearce, EN. Maternal Perchlorate Levels in Women With Borderline Thyroid Function During Pregnancy and the Cognitive Development of Their Offspring: Data From the Controlled Antenatal Thyroid Study. 2014. Journal of Clinical Endocrinology and Metabolism 99:4291-4298.

<sup>59</sup> Zewdie, T, Smith, CM, Hutcheson, M, Rowan West, C. Basis of the Massachusetts reference dose and drinking water standard for perchlorate. 2010. Environmental Health Perspectives 118:42-48.

Massachusetts Department of Environmental Protection (MassDEP) criticized how the RfD was developed by the NAS Committee. It said that the NAS Committee treated the lowest dose given to the healthy adult individuals in the Greer et al.<sup>60</sup> study as a no-effect level when the lowest dose indeed caused a 5% inhibition of iodine uptake. The agency determined that the NAS Committee's reliance on the lowest dose was not protective enough because, according to MassDEP, no objective data describing a level of iodine uptake inhibition that would cause no downstream effect has been identified. MassDEP used additional uncertainty factors to compensate for lack of data.

In 2013, the Environmental Protection Agency's (EPA) Science Advisory Board (SAB) also concluded that the NAS Committee's RfD for perchlorate was insufficient to protect the most vulnerable population.<sup>61</sup> In 2015, California Environmental Protection Agency (CalEPA) increased the uncertainty factors added to the RfD after considering recent toxicology and epidemiology studies on exposures focusing on infants.<sup>62,63</sup>

As mentioned above, FDA also ignored basic toxicology principles in dealing with incomplete data. Section 402(c)(5)(C) of the FD&C Act requires that when evaluating a food additive petition, FDA must consider "safety factors which in the opinion of experts qualified by scientific training and experience to evaluate the safety of food additives are generally recognized as appropriate for the use of animal experimentation data." (21 U.S.C. § 348(c)(5)(C)).

In its analysis of the health risk posed by perchlorate, the agency stated that the RfD was protective of all populations because the NAS Committee used a "conservative approach" by choosing iodine uptake inhibition—a non-adverse effect—as the point of departure and an uncertainty factor of 10 was sufficient to compensate for intraspecies differences. FDA also appears to agree with EPA's approach that 10 is the default intraspecies value and that the uncertainty factor "accounts not only for the potential difference in the IUI [iodine uptake inhibition] between the healthy adult subjects of the Greer et al (2002) study and the sensitive population identified by the [NAS Committee] (*i.e.*, fetuses of pregnant women with hypothyroidism), but for differences in perchlorate sensitivity across the entire population (including fetuses of hypothyroxinemic women)."<sup>64</sup>

We disagree. FDA must demonstrate that there is reasonable certainty that a 5% reduction in iodine uptake will cause no harm to the children born to the 20% of pregnant women whose consumption of iodine is already below what EPA has stated is medically

---

<sup>60</sup> Greer et al 2002.

<sup>61</sup> EPA, Science Advisory Board Advice on Approaches to Derive a Maximum Contaminant Level Goal for Perchlorate, 2013. See <https://www.epa.gov/dwstandardsregulations/perchlorate-drinking-water>.

<sup>62</sup> OEHHA Adopts Updated Public Health Goal for Perchlorate. Press Release. February 27, 2015. See [http://oehha.ca.gov/public\\_info/press/PerchloratePHGpress2015.pdf](http://oehha.ca.gov/public_info/press/PerchloratePHGpress2015.pdf).

<sup>63</sup> California Environmental Protection Agency Office of Environmental Health Hazard Assessment. Final technical support document on the public health goal for: perchlorate in drinking water. See <http://oehha.ca.gov/water/phg/2015perchlorate.html>.

<sup>64</sup> FDA, FAP 4B4808 Toxicology Analysis, March 31, 2017, Docket FDA-2015-F-0537-0042, pages 9-10.

insufficient. We concur with the MassDEP conclusion<sup>65</sup> that no objective data has been identified that describes a level of iodine uptake inhibition that would not cause a downstream effect.

We agree with the agency that iodine uptake inhibition is a “precursor event” in the mode of action of perchlorate including any effect that occurs further downstream, such as lowering thyroid hormone T4. However, FDA has not indicated what percentage of inhibition it considers will cause no effect. Population data show that thyroid hormone alteration may occur at less than 5% iodine inhibition. Also, a 2008 EPA modeling study<sup>66</sup> predicted that perchlorate exposures of 0.066 µg/kg/day could cause less than 1% reduction in iodine uptake inhibition. This level is the median U.S. perchlorate dose stemmed from the 2001-2002 NHANES data<sup>67</sup> and it is 10 times lower than the NAS Committee’s RfD of 0.7 µg/kg/day.

Additionally, FDA failed to consider sustained exposure to perchlorate. According to the CDC, every American tested has the chemical in their body. There is growing evidence of perchlorate exposures associated with thyroid hormone alterations in women with insufficient iodine intake.<sup>68,69</sup> A recent study of more than 1,800 pregnant women concluded that “environmental exposures to perchlorate impact thyroid hormone production during pregnancy which could have implication for public health given the widespread perchlorate exposure and the critical importance of thyroid hormone in fetal neurodevelopment.”<sup>70</sup> All this information complements EPA’s conclusion that pregnant women with iodine intake considered medically insufficient cannot be exposed to any perchlorate.

Normal fetal brain development is the result of an undisturbed harmonious interaction among cells, and between cells and hormones. If a step is missed or occurred at the wrong time, the fetus does not compensate. If developmental processes are disrupted by lowering thyroid hormone due to perchlorate exposure, this most likely creates permanent deficits. Perchlorate interferes with the thyroid gland’s ability to use iodine from the diet, a critical element to make a thyroid hormone, known as T4. This hormone plays an important role in the body regulating metabolism and, most critically, fetal and infant

---

<sup>65</sup> Zewdie, T, Smith, CM, Hutcheson, M, Rowan West, C. Basis of the Massachusetts reference dose and drinking water standard for perchlorate. 2010. *Environmental Health Perspectives* 118:42-48.

<sup>66</sup> U.S. EPA. Interim Drinking Water Health Advisory for Perchlorate. 2008. Washington, DC.

<sup>67</sup> Blount, BC, Pirkle, JL, Osterloh JD, Valentin-Blasini, L, Caldwell, KL. Urinary perchlorate and thyroid hormone levels in adolescent and adult men and women living in the United States. 2006. *Environmental Health Perspectives* 114:1865–1871.

<sup>68</sup> Blount, BC, Valenti-Blasini, L. Analysis of perchlorate, thiocyanate, nitrate and iodide in human amniotic fluid using ion chromatography and electrospray tandem mass spectrometry. 2006. *Analytical Chimica Acta* 567(1):87–93.

<sup>69</sup> Steinmaus, C, Miller, MD, Howd, R. Impact of smoking and thiocyanate on perchlorate and thyroid hormone associations in the 2001–2002 National Health and Nutrition Examination Survey. 2007. *Environmental Health Perspectives* 115:1333–1338.

<sup>70</sup> Steinmaus, C, Pearl, M, Kharrazi, M, Blount, BM, Miller, MD, Pearce, EN, Valentin-Blasini, L, DeLorenze, G, Hoofnagle, AN, Liaw, J. Thyroid hormones and moderate exposure to perchlorate during pregnancy in women in southern California. 2016. *Environmental Health Perspectives* 24(6):861-7.

brain development.<sup>71</sup> Inadequate levels of T4 during pregnancy<sup>72</sup> and in the first years of life are likely to affect a child's ability to reach his or her full intellectual potential. There is evidence that children born to mothers with borderline iodine deficiency that were exposed to perchlorate in the first trimester show signs of delayed development.<sup>73</sup>

In addition, the agency improperly dismissed EPA's updated dose-response model because the peer review process was not completed. This dose-response model was based on a previous version developed by FDA's scientist and EPA expects to use it to implement the SAB's recommendation. FDA's scientific analysis of FAP No 4B4808 petition did not go through any third party scrutiny or peer review. Simply dismissing EPA's analysis because the agency sought the scrutiny that FDA has avoided is improper.

Finally, FDA's analysis also ignored its own data. In 2016, the agency's scientists published an estimate of perchlorate consumption for infants and toddlers showing that toddlers 2-year olds could be exposed to 0.80 µg/kg bw/d, a level above NAS committee's RfD on which FDA relied. See Figure 5. Surprisingly, this very important data was never mentioned in the agency's rationale to reject FAP No. 4B4808.

These levels alone are alarming because of the risk of irreversible harm to brain development. Yet, FDA report did not address additional exposure factors that further contribute to the risk of perchlorate in food:

- Contribution of [perchlorate from drinking water](#), a source that is significant enough that EPA is currently developing standards to protect people;
- Exposure to nitrates and thiocyanate in the diet, which can also impair the thyroid; and
- Levels in food may have continued to increase in the four years since the samples were collected.

Many young children may be over the NAS Committee's RfD and at risk of irreversible harm. Organ development, including that of the brain, is a one-way street where a series of "tightly regulated and temporally coordinated events" take place to produce a functional structure.<sup>74</sup> Simply put, there is only one chance to get it right. After birth, the brain continues to develop for many years. In 2010, researchers from the CDC showed that perchlorate was a contaminant of all commercially available powdered infant formulas they tested and that the NAS Committee's RfD "may be exceeded when certain

---

<sup>71</sup> Maffini et al, 2016.

<sup>72</sup> EPA, SAB Advice on Approaches to Derive a Maximum Contaminant Level Goal for Perchlorate, 2013. See <https://www.epa.gov/dwstandardsregulations/perchlorate-drinking-water>.

<sup>73</sup> Taylor, P.N. et al. Maternal Perchlorate Levels in Women With Borderline Thyroid Function During Pregnancy and the Cognitive Development of Their Offspring: Data From the Controlled Antenatal Thyroid Study. 2014. J Clin Endocrinol Metab 99:4291-4298.

<sup>74</sup> Gore, AC, Chappell, VA, Fenton, SE, Flaws, JA, Nadal, A, Prins, GS, Toppari, J, Zoeller, RT. EDC-2: The Endocrine Society's Second Scientific Statement on Endocrine-Disrupting Chemicals. 2015. Endocrine Reviews 36(6):E1-E150.

**Figure 5. Perchlorate Intake of Infants, Toddlers, and Children from 2008-2012 Total Diet Study Data as baby food in 2005 and in 2008 to 2012.**

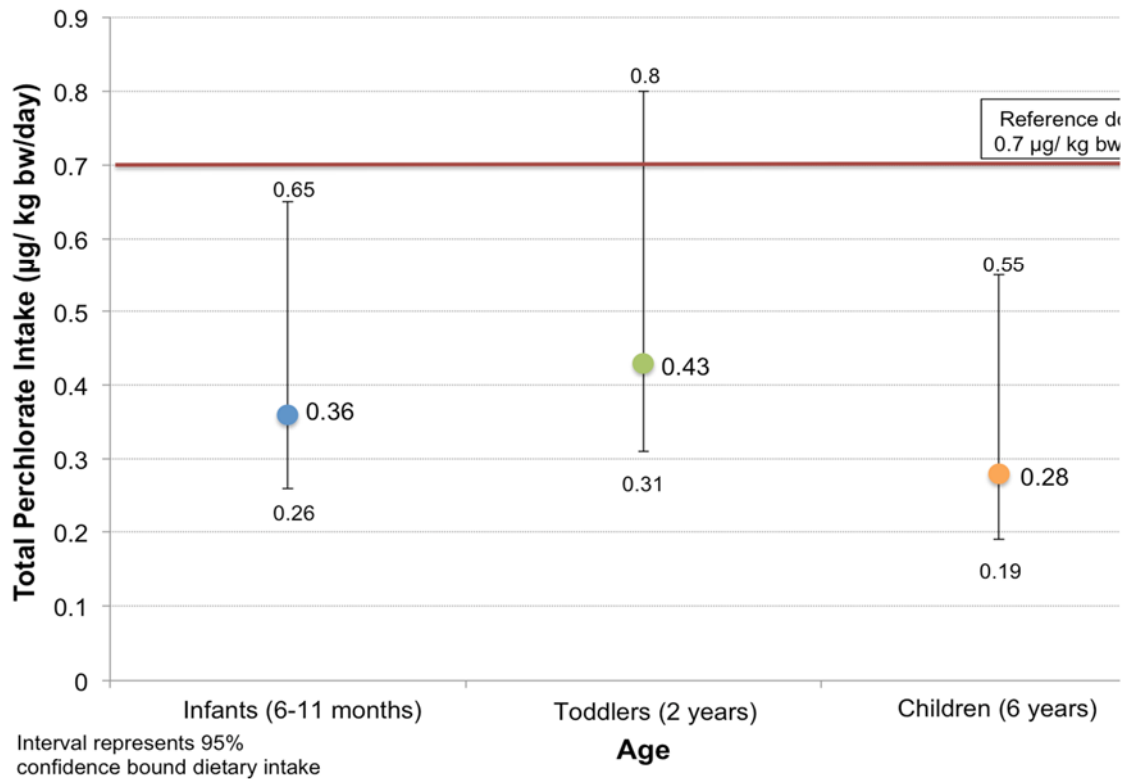

bovine milk-based powdered infant formulas are ingested and/or when powdered infant formulas are reconstituted with perchlorate-contaminated water.<sup>75</sup>

If the agency had properly considered the toxicology of perchlorate, especially its effect on pregnant women with severe iodine deficiency, applied appropriate safety factors, and considered its own data on children consumption of perchlorate, it would have found that the TOR decision was not proper and, therefore, FAP No. 4B4808 was should have been accepted, not denied.

For these reasons, we request a formal evidentiary public hearing to present evidence and receive testimony from experts about its merits of this objection.

<sup>75</sup> Schier, JG, Wolkin, AF, Valentin-Blasini, L, Belson, MG, Kieszak SM, Rubin, CS, Blount, BC. Perchlorate exposure from infant formula and comparisons with the perchlorate reference dose. 2010. *Journal of Exposure Science and Environmental Epidemiology* 20:281–7.

**Objection 1G: FDA failed to consider that perchlorate-laden plastic has a technical effect on the food to which it migrates by reducing the accumulation of a static charge in the food. This technical effect means it is not eligible for a TOR.**

Pursuant to 21 CFR § 170.39(a)(3), a substance is only eligible for a TOR if it “has no technical effect in or on the food to which it migrates.” As discussed in Objection 1C, the purpose of an anti-static agent such as perchlorate is to dissipate the charge that might otherwise accumulate from the flowing dry food, which should be considered a technical effect on the food to which it migrates. Therefore, it is ineligible for a TOR exemption under the terms of FDA’s rule.

A static charge can be generated when a dry solid flows. When the solid is flowing across a non-conductive material, such as a typical plastic, the static charge can accumulate. If the accumulated charge reaches a high enough level, it can produce a spark that can ignite the powder and cause a dust explosion.

For these reasons, we request a formal evidentiary public hearing to present evidence and receive testimony from experts about the merits of this objection.

**Objection 2: FDA accepted all three petitioner requests as properly filed as FAP No. 4B4808 and issued a public notice in the Federal Register inviting public comments on all three requests as proper to a food additive petition. Then, without notice to the petitioners or the public, FDA determined that Requests A and B were not eligible for consideration as food additive petitions. This interpretation was contrary to law.**

Pursuant to 21 CFR § 171.1(i)(1)(i), FDA notified the petitioners by letter dated December 31, 2014, that the FAP No. 4B4808 had three requests, and that the agency determined the petition was appropriate for filing.<sup>76</sup> It accepted all three requests for filing and did not make any statement that Request A or B were not proper to a food additive petition or had a provisional status. The agency simply said that “The petition has been filed.”<sup>77</sup>

FDA affirmed its decision that all three requests were appropriate to a food additive petition when it published, pursuant to 21 CFR § 171.1(i)(2), the notice in the *Federal Register* announcing that it had filed FAP No. 4B4808.<sup>78</sup> The agency provided a detailed description of each of the requests and said “Under section 409(b)(5) of the Federal Food, Drug, and Cosmetic Act (the FD&C Act) (21 U.S.C. 348(b)(5)), we are giving notice that we have filed a food additive petition (FAP 4B4808). . .”<sup>79</sup> Nowhere in the notice does FDA suggest that Requests A and B were not eligible for consideration in a food additive petition. In addition, we found no suggestion in the public comments to the petition that the requests were not eligible.

---

<sup>76</sup> Letter from FDA’s Paul Honigfort to NRDC’s Erik Olson, RE: Food Additive Petition (FAP) No. 4B4808, December 31, 2014. See Docket No. FDA-2015-F-0537-0014.

<sup>77</sup> *Id.*

<sup>78</sup> FDA, Natural Resources Defense Council et al.; Filing of Food Additive Petition, 80 Fed.Reg. 13508, March 16, 2015. See Docket No. FDA-2015-F-0537-0001.

<sup>79</sup> *Id.* at 13509.

On March 31, 2015, FDA sent a letter to petitioners stating that it had extended the scientific review of the petition for an additional 90 days pursuant to FD&C Act Section 409(c)(2).<sup>80</sup> The letter indicated that FDA continued to consider all three requests eligible for consideration in a food additive petition.

On July 10, 2015, FDA posted to the docket a memorandum of a meeting with industry representatives on May 18, 2015.<sup>81</sup> The memo continued to consider all three requests as eligible for consideration in a food additive petition.

On August 17, 2015, FDA provided petitioners with a memorandum describing conference calls with petitioners on June 25, 2015 and August 7, 2015 regarding the status of FAP No. 4B4808. The agency reaffirmed that it was actively evaluating all three requests.<sup>82</sup> There is no suggestion that Requests A and B were ineligible for consideration in a food additive petition.

On January 26, 2016, FDA provided petitioners with a memorandum describing a January 15, 2016 conference call with petitioners.<sup>83</sup> The agency “informed the petitioners that the Office of Food Additive Safety (OFAS) has made significant progress on the technical review of FAP 4B4808 and that it expected the technical review would be completed sometime near the end of February, 2016.”<sup>84</sup> The memo continued to consider all three requests as eligible for consideration in a food additive petition.

The first indication that FDA had altered its views and deemed Requests A and B as ineligible for consideration in a food additive petition was in the agency’s response to a writ of mandamus filed in the 9<sup>th</sup> Circuit Court of Appeals by some, but not all of the petitioners. In its July 8, 2016 Opposition to a Petition for a Writ of Mandamus, FDA states: “Although the petition is styled as a “food additive petition,” it requests three types of relief. Only one of these requests could be appropriately characterized as a food additive petition.”<sup>85</sup> Because the parties filed a Joint Motion to Modify Briefing Schedule and Stay Proceedings,<sup>86</sup> the court did not rule on FDA’s reinterpretation.

In its decision to deny FAP No. 4B4808, FDA stated that Requests A and B were not directed at regulations issued under the food additive petition process and, therefore, “are governed by different regulations and are not subject to the statutory processes for food additive petitions.”<sup>87</sup>

---

<sup>80</sup> FDA, Letter from FDA’s Francis Lin to NRDC’s Erik Olson, RE: Food Additive Petition (FAP) No. 4B4808. March 31, 2014. See Docket No. FDA-2015-F-0537-0015.

<sup>81</sup> FDA, Memorandum of Meeting, Re: Meeting with the Society of the Plastics Industry (SPI) and BASF Corporation regarding the allowed use of perchlorates in food contact applications, July 10, 2015. See Docket No. FDA-2015-F-0537-0010.

<sup>82</sup> FDA, Memorandum of Teleconference, RE: Teleconference with the submitters of Food Additive Petitions (FAPs) 4B4808 and 4B4809, August 7, 2015. Not posted to docket.

<sup>83</sup> FDA, Memorandum of Teleconference, RE: Teleconference with the submitters of Food Additive Petition (FAP) 4B4808, January 26, 2016. Not posted to docket.

<sup>84</sup> *Id.*

<sup>85</sup> *Breast Cancer Fund; et al. v. FDA*, No 16-70878 (9<sup>th</sup> Cir. July 8, 2016) (Opposition to a Petition for a Writ of Mandamus).

<sup>86</sup> *Breast Cancer Fund; et al. v. FDA*, No 16-70878 (9<sup>th</sup> Cir. July 25, 2016) (Joint Motion to Modify Briefing Schedule and Stay Proceedings).

<sup>87</sup> FDA, Denial of Food Additive Petition, 80 Fed.Reg. at 20850.



Regarding Request A, FDA said:

TOR substances, i.e., substances used in food-contact articles that become a component of food at levels that are below the threshold of regulation and meet the criteria in § 170.39, are exempt from regulation as food additives and do not require a listing regulation or food additive petition (see §§ 170.3(e)(2) and 171.8). As noted in the filing notice for this petition, the procedures for reevaluating and revoking a TOR exemption are set forth in § 170.39(g). These procedures are distinct from the food additive petition process. A request to revoke a TOR exemption is the proper subject of a citizen petition submitted under 21 CFR 10.30.<sup>88</sup>

Regarding Request B,

The petition's request that we issue a new regulation under part 189 also falls outside the scope of a food additive petition. A proposed part 189 regulation does not propose the issuance of a new food additive regulation or the amendment or repeal of an existing food additive regulation (see sections 409(b)(1) and (i) of the FD&C Act). Under part 189, an interested person can use the citizen petition process to request a regulation prohibiting a substance from human food (see § 189.1(c) (referring to 21 CFR part 10, which sets forth FDA's citizen petition process)).<sup>89</sup>

The agency considered Requests A and B as outside the scope of a food additive petition for purposes of administrative efficiency. However, it stated that "Our denial of these two requests is a final Agency decision, but is not an order under section 409(c)(1)(B) of the FD&C Act."<sup>90</sup>

We object to this determination for the reasons described below.

**Objection 2A: FDA accepted the three requests in FAP No. 4B4808 for filing, publicly noticed this decision, and invited public comment on the basis of this decision. Therefore, it is arbitrary and capricious for the agency to unilaterally reverse its position without explaining why its initial interpretation was flawed.**

In reinterpreting the scope of a food additive petition, the agency never explained:

- Why its original decision to file all three requests as a food additive petition was flawed.
- Why its reinterpretation first became public more than one year after the June 2015 statutory deadline under the section 409(c)(2) (21 U.S.C. § 348(c)(2)) to make a decision.

---

<sup>88</sup> *Id.*

<sup>89</sup> *Id.*

<sup>90</sup> *Id.* at 20850.

- Why it never formally notified the food additive petitioners of its decision on the two requests in the May 4, 2017 decision. Not all the food additive petitioners were a party to the petition for a writ of mandamus.
- Why it never offered the petitioners an opportunity to supplement the food additive petition as required by 21 CFR § 171(i)(1)(ii) after FDA reinterpreted the petition as “deficient.”

For these reasons, we request a formal evidentiary public hearing to present evidence and receive testimony from experts about the merits of this objection.

**Objection 2B: FDA’s decision that Request A in FAP No. 4B4808 was ineligible for a food additive petition because it was eligible for a Threshold of Regulation (TOR) was arbitrary, capricious and contrary to law.**

In Request A, petitioners asked FDA to revoke its 2005 approval of TOR No. 2005–006 allowing as much as 1.2 percent sodium perchlorate monohydrate in dry food packaging.<sup>91</sup>

The petitioners presented detailed reasoning why the original use of the perchlorate in dry food contact articles was eligible for a TOR and, therefore, was a food additive. In denying the request, the agency’s analysis found, after receiving additional tests that were not part of the agency’s original decision, that it was eligible for a TOR. As explained under Objection 1, this determination was scientifically flawed on numerous counts.

For these reasons, we request a formal evidentiary public hearing to present evidence and receive testimony from experts about the merits of this objection.

**Objection 2C: FDA’s decision that Request B in FAP No. 4B4808 was ineligible for a food additive petition because it requested a prohibition on the use of perchlorate in dry food packaging was arbitrary, capricious and contrary to law.**

In Request B, petitioners asked FDA to issue a new § 189.301 (21 CFR § 189.301) prohibiting the use of perchlorate as a conductivity enhancer in the manufacture of antistatic agents to be used in food contact articles.

FDA’s decision that a request for a prohibition on a specific use of a substance under 21 CFR Part 189 is outside the scope of a food additive petition is illogical. The agency’s decision in the early 1970s to put prohibitions under Part 189 was an administrative

---

<sup>91</sup> Note that in 2016, FDA modified the description of TOR Exemption No. 2005-006 to expand its scope from polymeric packaging to any polymeric food contact article, which would include packaging and food handling and processing equipment. After reviewing the agency’s documentation, it appears this change was made to be consistent with its original decision. While the agency fails to evaluate the implications of the change in its analysis, we maintain that it was obligated to do so.

decision that cannot serve as the basis to improperly narrow the scope of Section 409 under the FD&C Act (21 U.S.C. § 348).

The statute states that “Any person may, with respect to any intended use of a food additive, file with the Secretary a petition proposing the issuance of a regulation prescribing the conditions under which such additive may be safely used.” Contrary to FDA’s interpretation narrowing the scope of the food additive petition, prohibiting a specific use is a condition on the safe use of a substance. In fact, for substances found to induce cancer when ingested by man or animal, it is the only possible condition of use allowed by the Section 409(c)(3)(A) of the FD&C Act (21 U.S.C. § 348(c)(3)(A). Congress could not have intended when it enacted the Food Additives Amendment of 1958 that the most important of conditions, and the one about which Congress was most concerned<sup>92</sup> – that cancer-causing substance must not be used – is beyond the reach of a food additive petition.

In seeking a prohibition, the petitioners essentially asked for a zero tolerance on the specific use. When the California legislature considered the issue of a ban on a chemical in the Sherman Food Drug and Cosmetic Law, it recognized that a zero tolerance was a condition of use by expressly authorizing the state’s department of public health to adopt “regulations that prescribe tolerances, included but not limited to zero tolerances, for poisonous or deleterious substances, food additives, pesticide chemicals, or color additives.”<sup>93</sup>

FDA’s improper narrowing of the statute essentially leaves the public with only the option of a citizen petition pursuant to 21 CFR § 10.30 to seek agency action. The Government Accountability Office has documented the agency’s long history of neglecting citizen petitions regarding food additives.<sup>94</sup>

Even FDA recognizes the importance of making clear that the use of a substance is prohibited. In its “Everything Added to Food in the United States (EAFUS)” database,<sup>95</sup> FDA includes substances that are prohibited under 21 CFR Part 189. For example a search for “Calamus” provides three results that say “Calamus Extract—Prohibited”, “Calamus Oil—Prohibited” and “Calamus—Prohibited” and references 21 CFR § 189.110.

---

<sup>92</sup> Chemical Additives in Food: Hearings on H.R. 4475 Before the Subcommittee On Health and Science of the House Committee On Interstate and Foreign Commerce, 84th Cong., 2d Sess. 30 (1956). One of the main purposes of the legislation, according to the Report accompanying the House Bill, was “to protect the health of consumers by requiring manufacturers of food additives and food processors to pretest any potentially unsafe substances which are to be added to food.” H. Rep. No. 85-2284 (July 28, 1958). The second purpose was to “advance food technology by permitting the use of food additives at safe levels.” Id. This was a response to the previously existing law, which “entirely prohibit[ed] the use of these additives [even] at safe levels.” Id. While this purpose promoted the use of additives, to a degree, it was only the safe use thereof, as policed by adequate premarket assessment.

<sup>93</sup> California Sherman Food, Drug, and Cosmetic Law (1970), Section 110070 codified as Division 104, Part 5 of the California Health and Safety Code.

<sup>94</sup> U.S. Government Accountability Office (GAO), FDA Should Strengthen Its Oversight of Food Ingredients Determined to Be Generally Recognized as Safe (GRAS), GAO-10-246 21 (Feb. 2010).

<sup>95</sup> FDA, Everything Added to Food in the United States (EAFUS), accessed May 20, 2017 at <https://www.fda.gov/food/ingredientpackaginglabeling/foodadditivesingredients/ucm115326.htm>.

The express prohibition on the use of perchlorate in food contact articles is even more important given the three different variations in the description of TOR No. 2005-006 posted on its website. Unlike a Food Contact Substance Notification, BASF's competitors were free to market their own product that were consistent with the online description. We maintain that only a clear repudiation would clear up the confusion created by FDA's failure to properly describe its original decision.

For these reasons, we request a formal evidentiary public hearing to present evidence and receive testimony from experts about the merits of this objection.

**Objection 3: FDA's failure to make a timely decision on FAP No. 4B4808 should not serve as an excuse to moot Request C that the agency remove its approval of perchlorate in gaskets for food containers. Such an approach is poor public policy and unfair to the petitioners.**

FDA had a statutory duty pursuant to section 409(c)(2) (21 U.S.C. § 348(c)(2)) to make a decision by the end of June 2015. On May 11, 2016, almost a year after the agency failed to meet the statutory deadline, FDA filed a food additive petition by the Society of Plastics Industry claiming that the use of perchlorate as a food additive in container gaskets pursuant to 21 CFR § 177.1210) was abandoned and sought public comment on June 30, 2016.<sup>96</sup>

The industry's petition was filed three months after the public interest community filed a petition for a writ of mandamus claiming unreasonable delay by the agency.<sup>97</sup> It is manifestly unfair for the agency to have used its failure to make a timely decision as the basis for mooting FAP No. 4B4808. It is also poor public policy because it discourages industry to file abandonment petitions except in the face of a petition that may find the use no longer safe.

For these reasons, we object to FDA's decision to allow the abandonment petition to moot FAP No. 4B4808. We also ask for a formal evidentiary public hearing on the issue to show that the abandonment petition was only filed after the agency should have already made a determination of FAP No. 4B4808 on the merits.

In summary, we object to FDA's decision and request a formal evidentiary public hearing as detailed above.

Sincerely,



Tom Neltner  
Environmental Defense Fund

---

<sup>96</sup> FDA, Society of the Plastics Industry, Inc.; Filing of Food Additive Petition, 81 Fed. Reg. 42585 (June 30, 2016).

<sup>97</sup> *Breast Cancer Fund; et al. v. FDA*, No 16-70878 (9<sup>th</sup> Cir. filed March 31, 2016).

1875 Connecticut Ave, NW, Suite 600  
Washington, DC 20902  
[tneltner@edf.org](mailto:tneltner@edf.org)  
202-572-3263

Erik Olson  
Natural Resources Defense Council

Nancy Buermeyer  
Breast Cancer Prevention Partners

Caroline Cox  
Center for Environmental Health

Cristina Stella  
Center for Food Safety

Laura MacCleery  
Center for Science in the Public Interest

Lynn Thorp  
Clean Water Action

Tina Sigurdson  
Environmental Working Group

Jack Leonard  
Improving Kids' Environment